



# Open Source Orgelbau

Benjamin Wand, Jannik Beyerstedt

---

*35th Chaos Communication Congress*





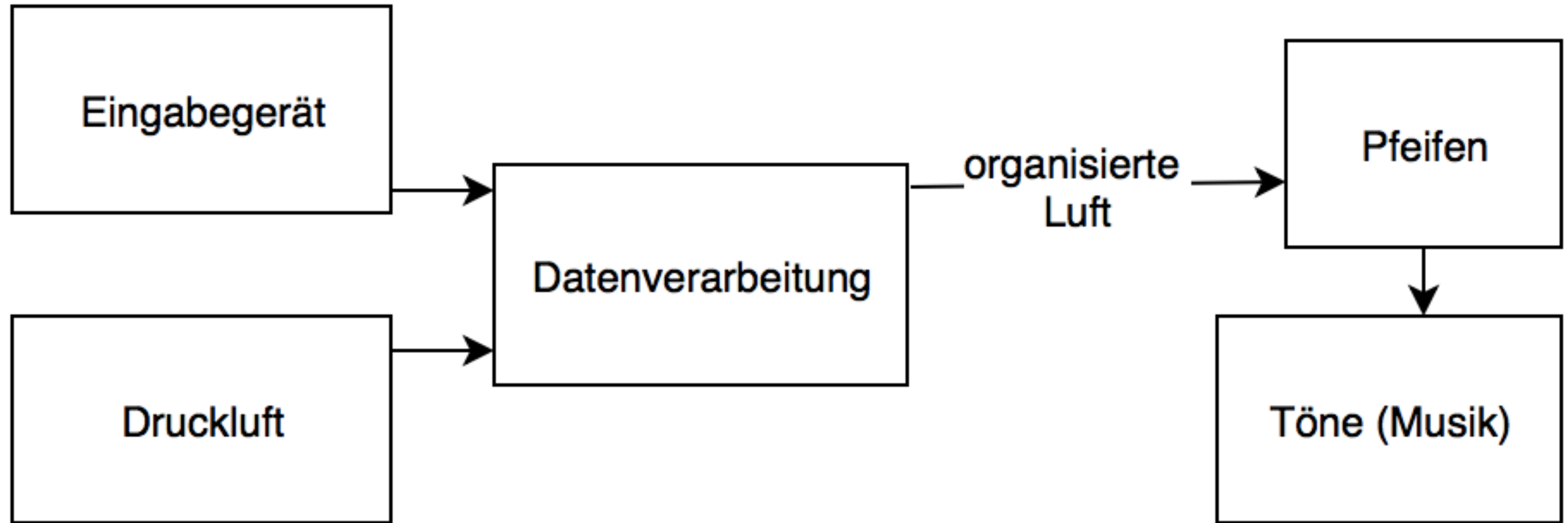

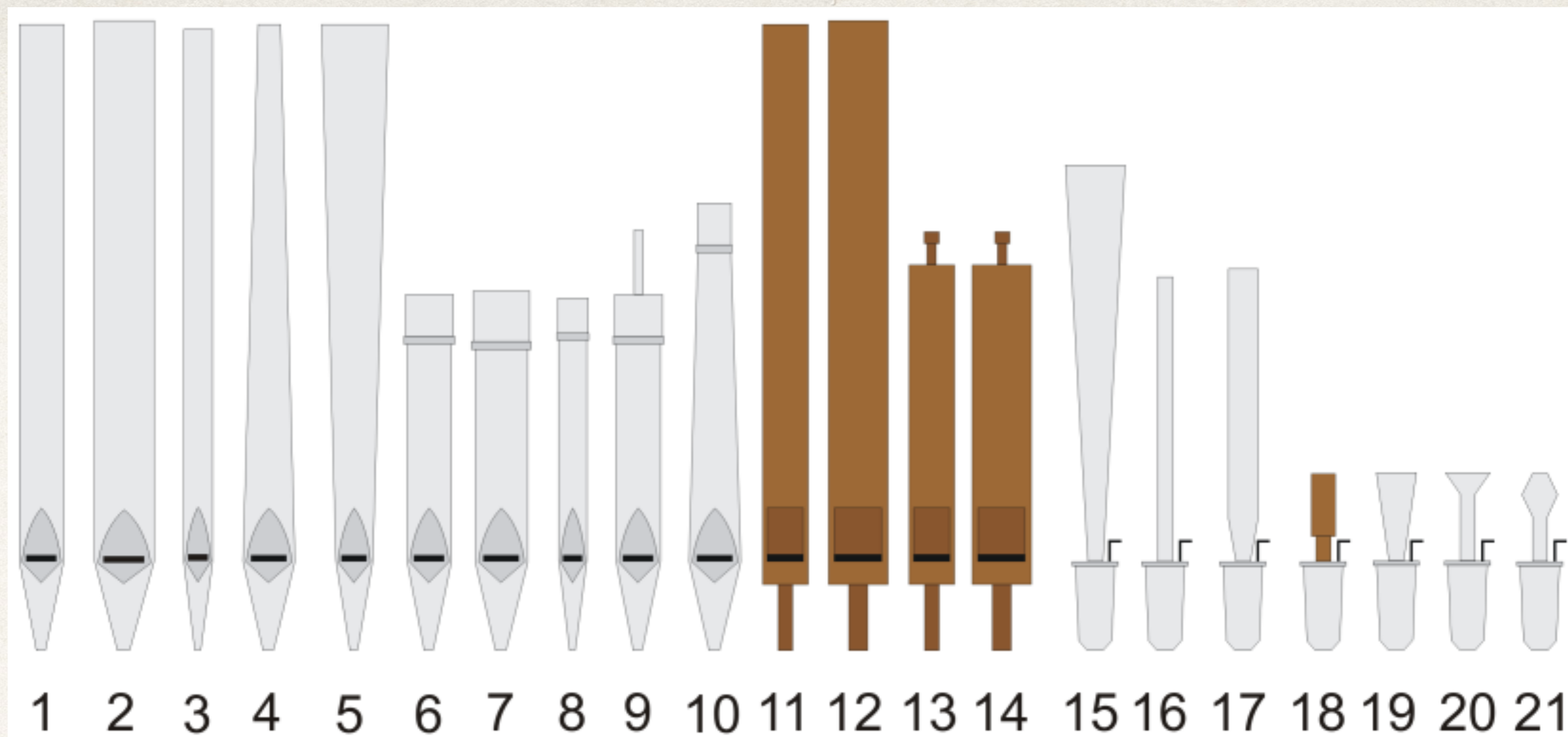

**Labialpfeifen:** (1) Prinzipal, (2) Offenflöte, (3) Gambe, (4) Spitzflöte, (5) Trichterflöte, (6) Gedackt, (7) Gedacktblöte, (8) Quintade, (9) Rohrflöte, (10) Spitzgedackt

**Labialpfeifen aus Holz:** (11) Prinzipal, (12) Offenflöte, (13) Gedackt, (14) Gedacktblöte

**Lingualpfeifen:** (15) Trompete, (16) Krummhorn, (17) Dulzian, (18) Holzregal, (19) Trompetenregal, (20) Trichterregal, (21) Doppelkegelregal



Windchest ([https://commons.wikimedia.org/wiki/File:Vox\\_Maris.JPG](https://commons.wikimedia.org/wiki/File:Vox_Maris.JPG)),  
„Vox Maris“, <https://creativecommons.org/licenses/by-sa/3.0/legalcode>

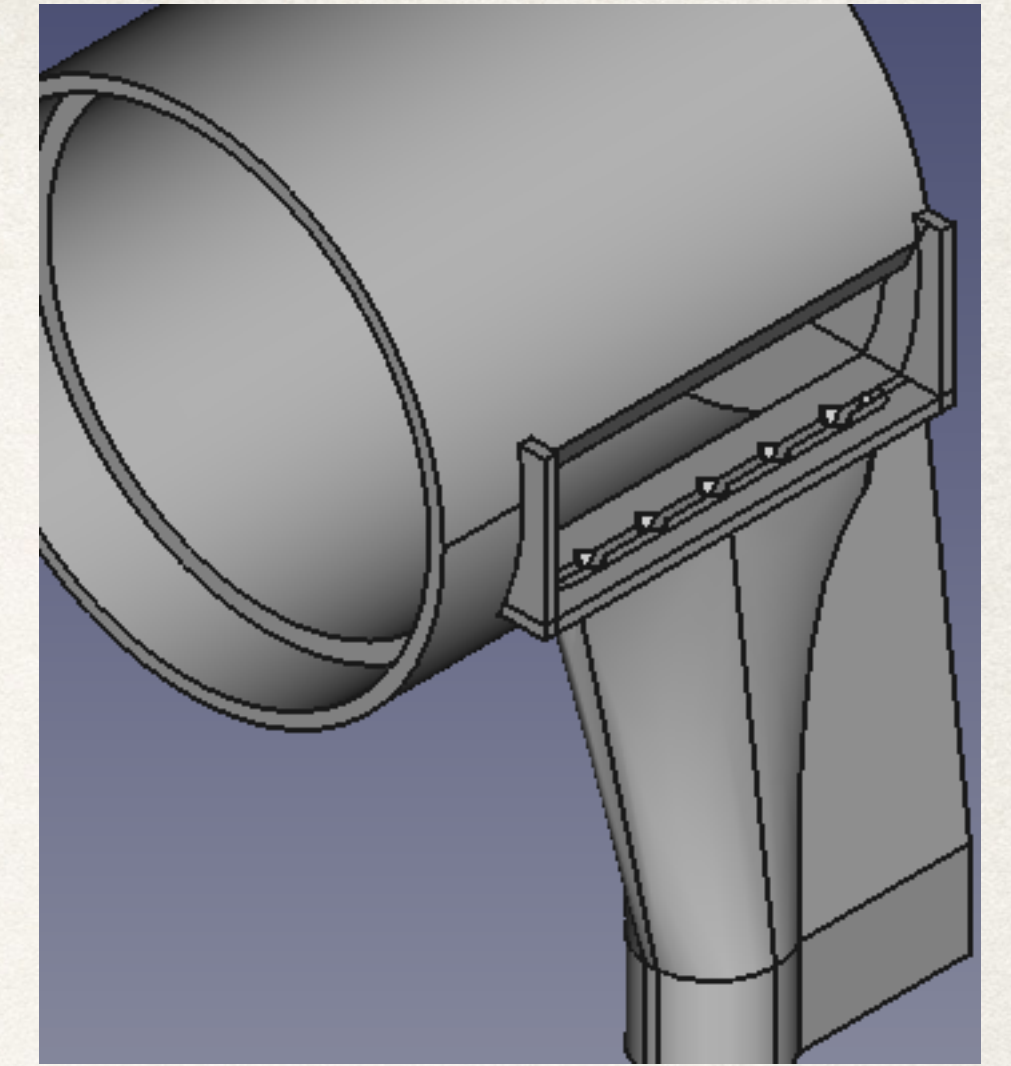
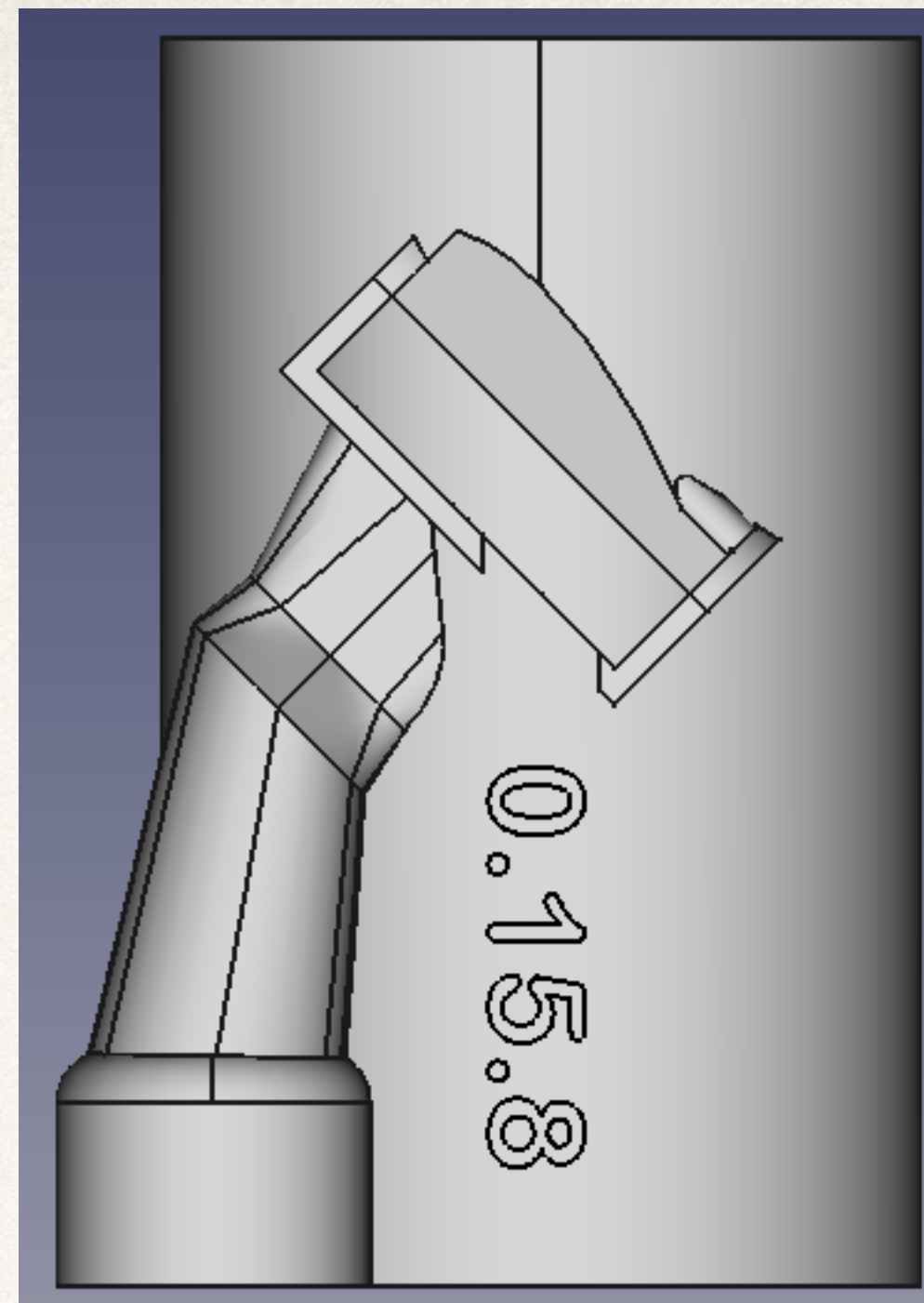
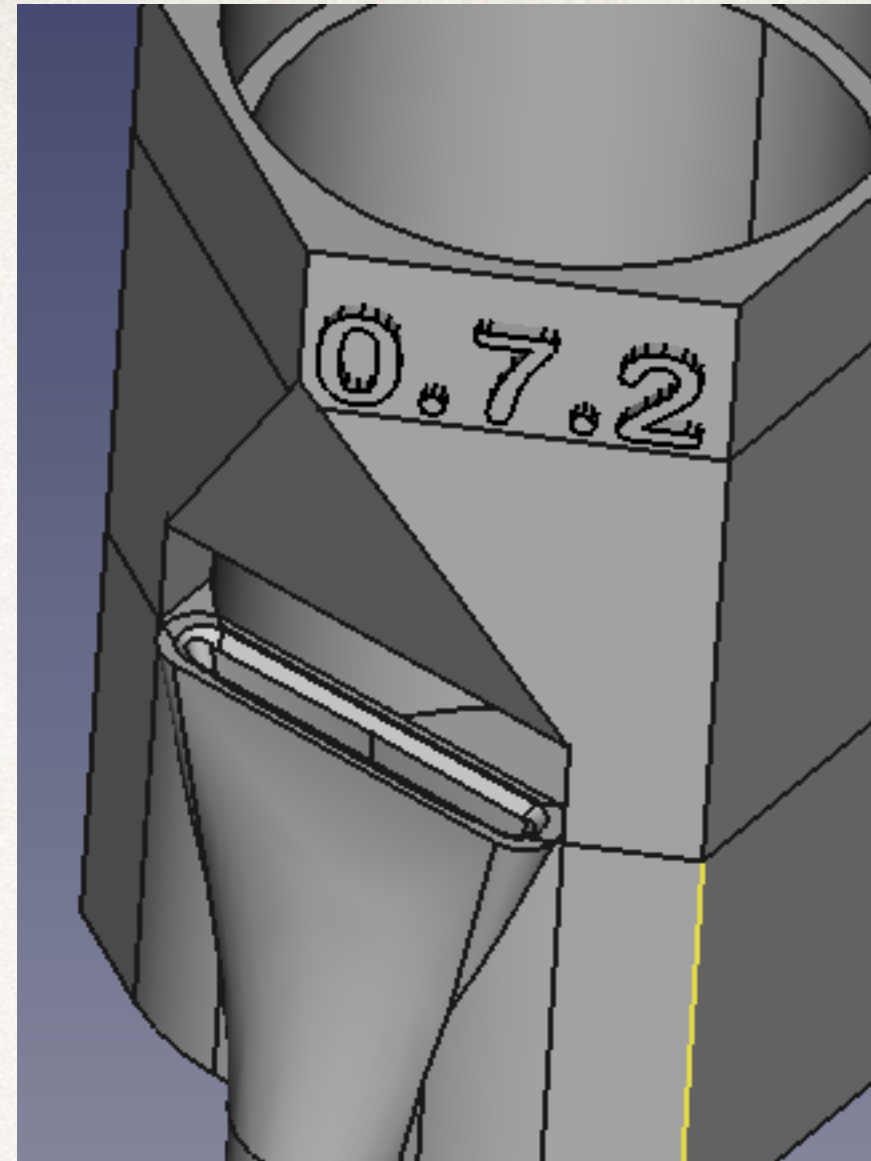
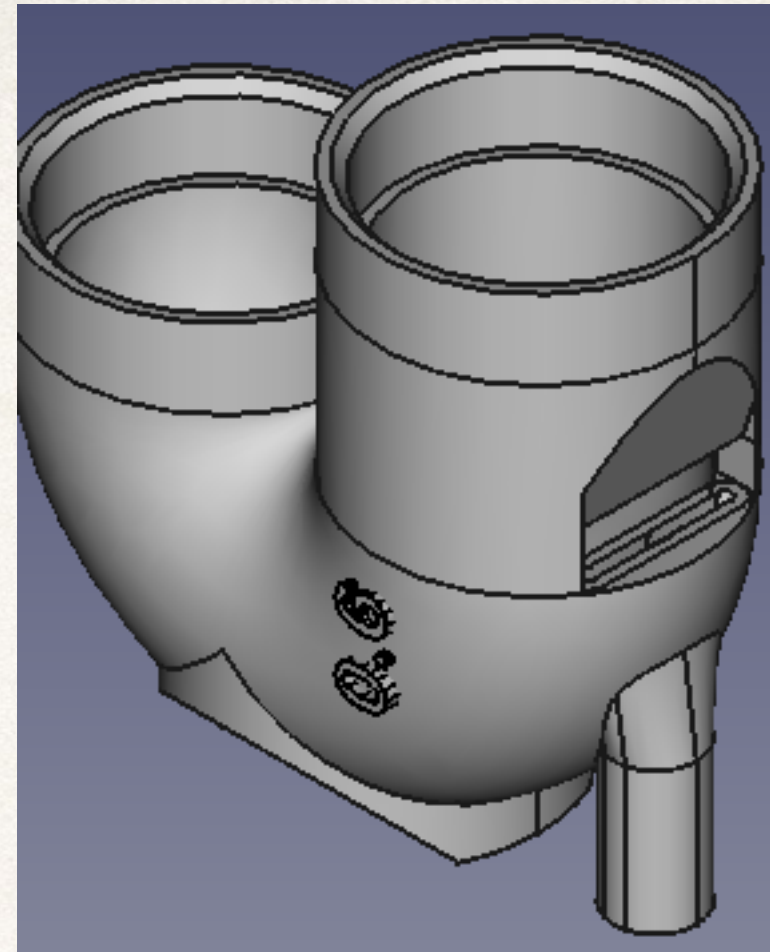
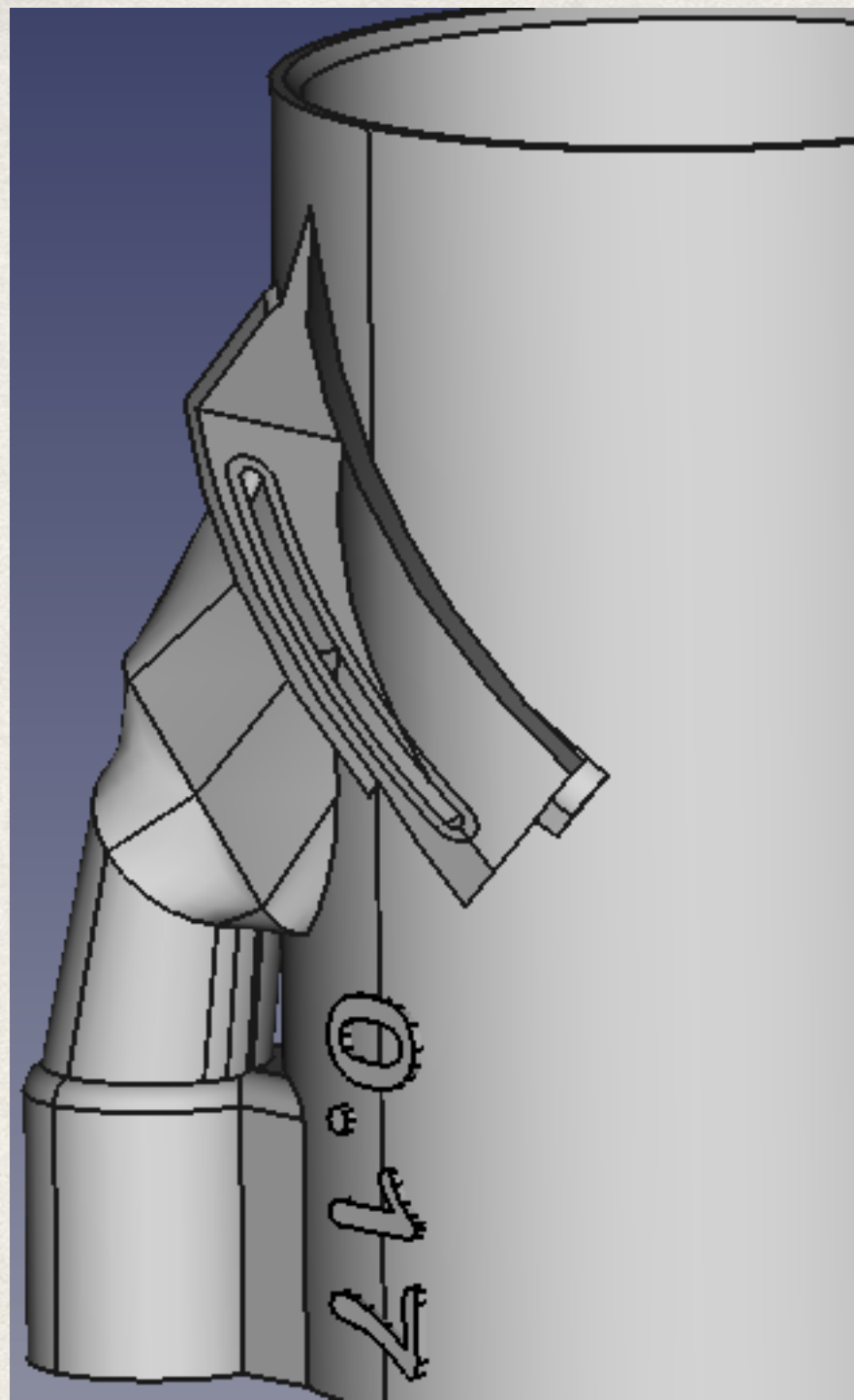

[github.com/benjaminwand/3d-printed-labial-pipe](https://github.com/benjaminwand/3d-printed-labial-pipe)

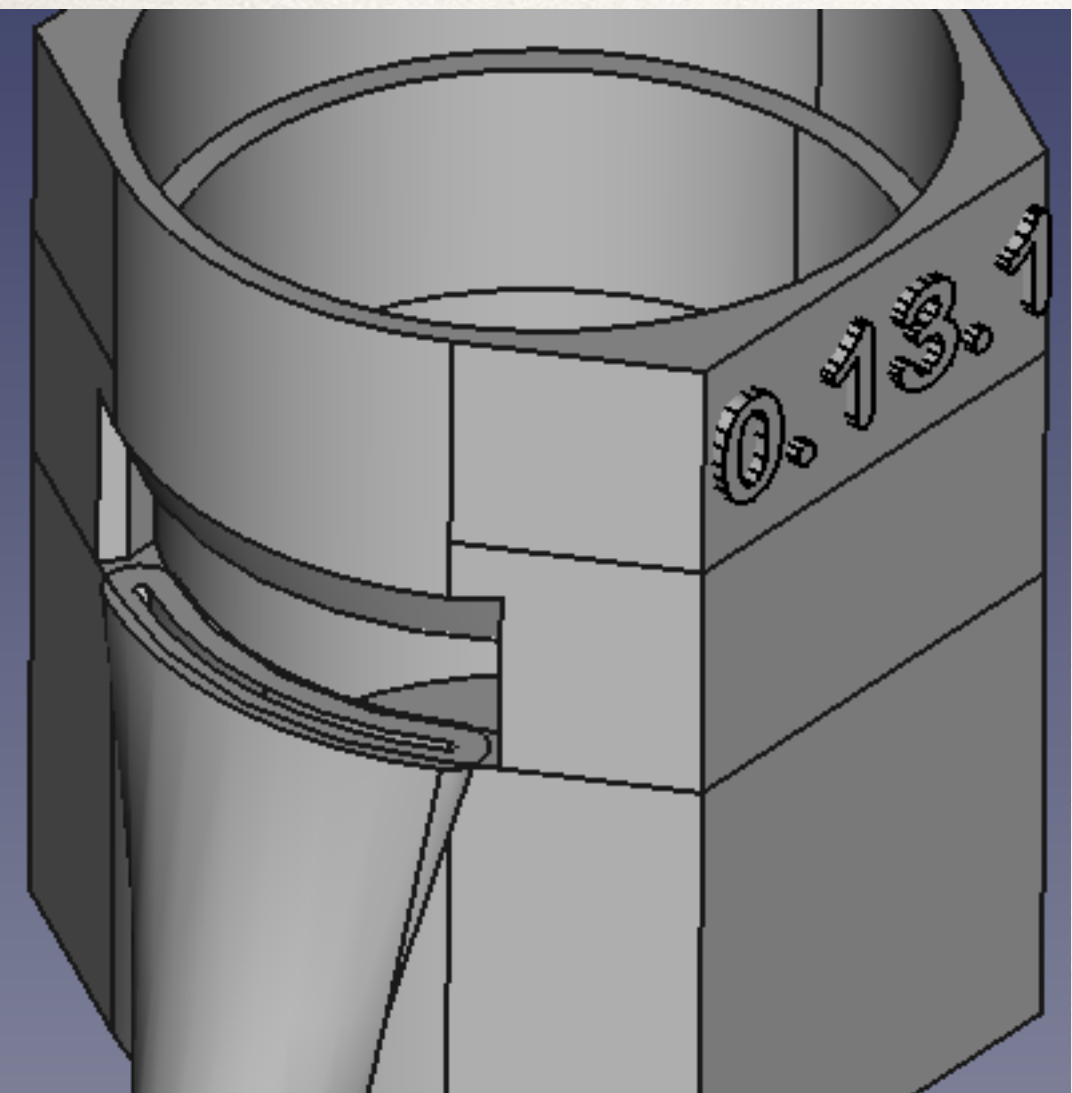
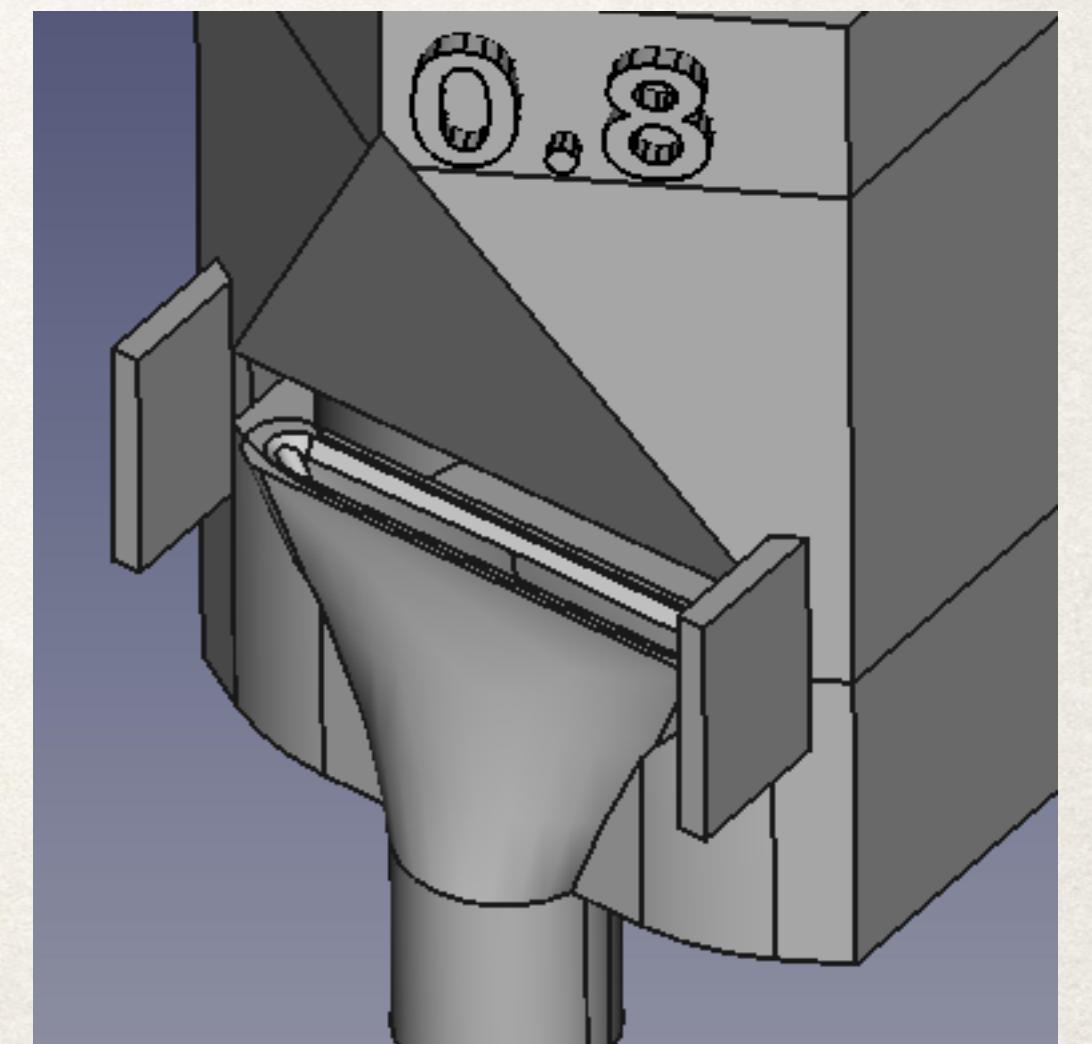
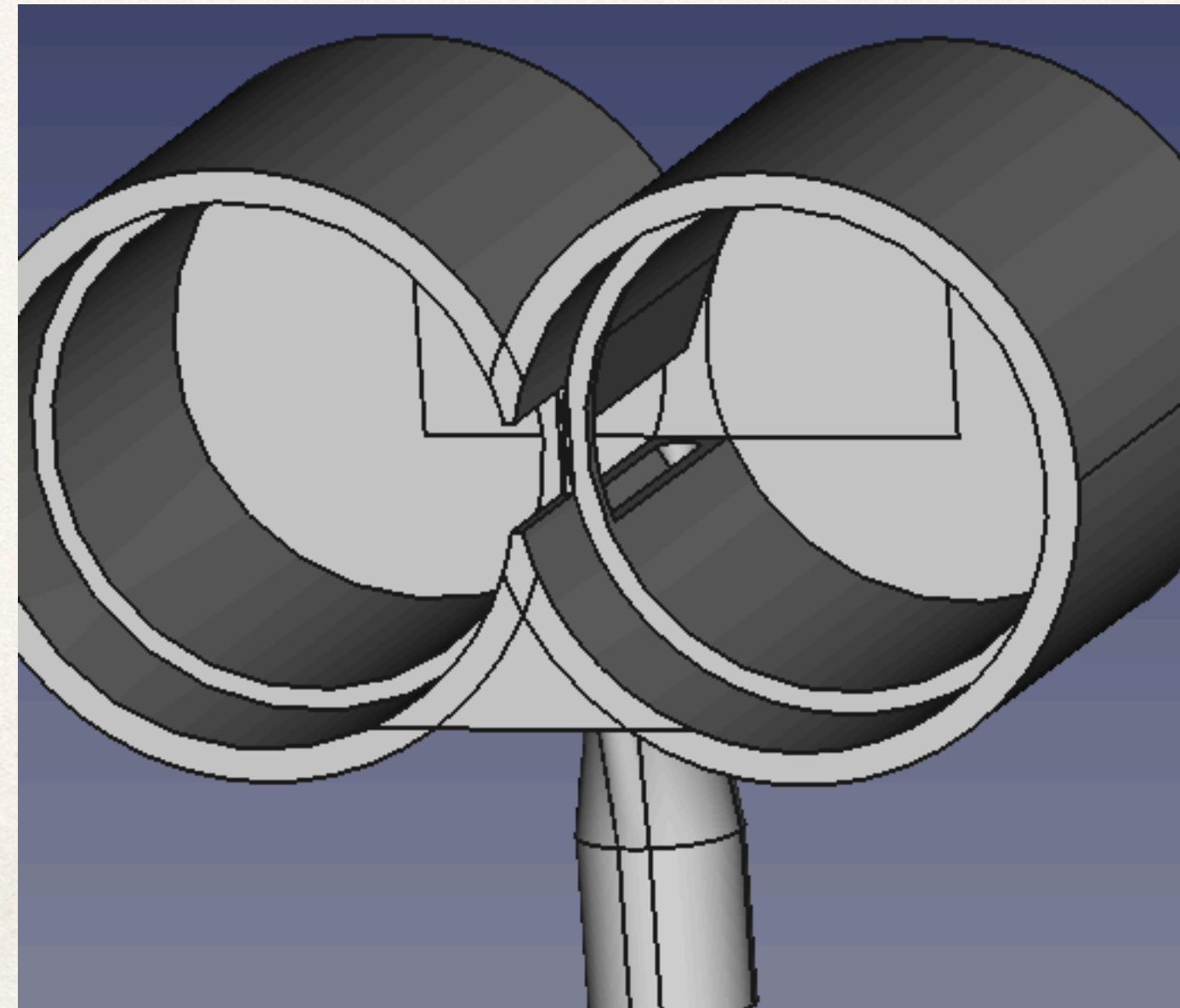
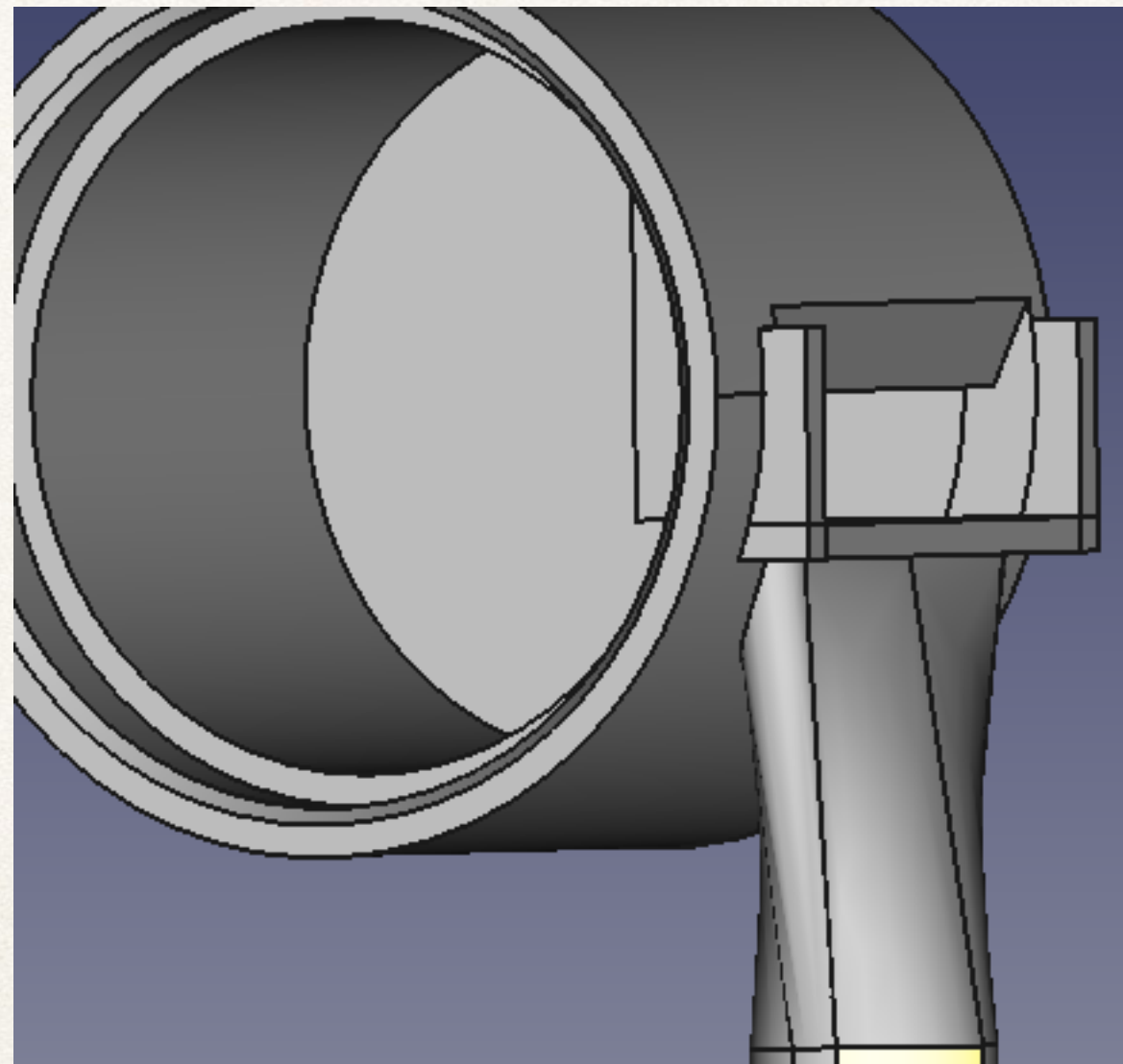

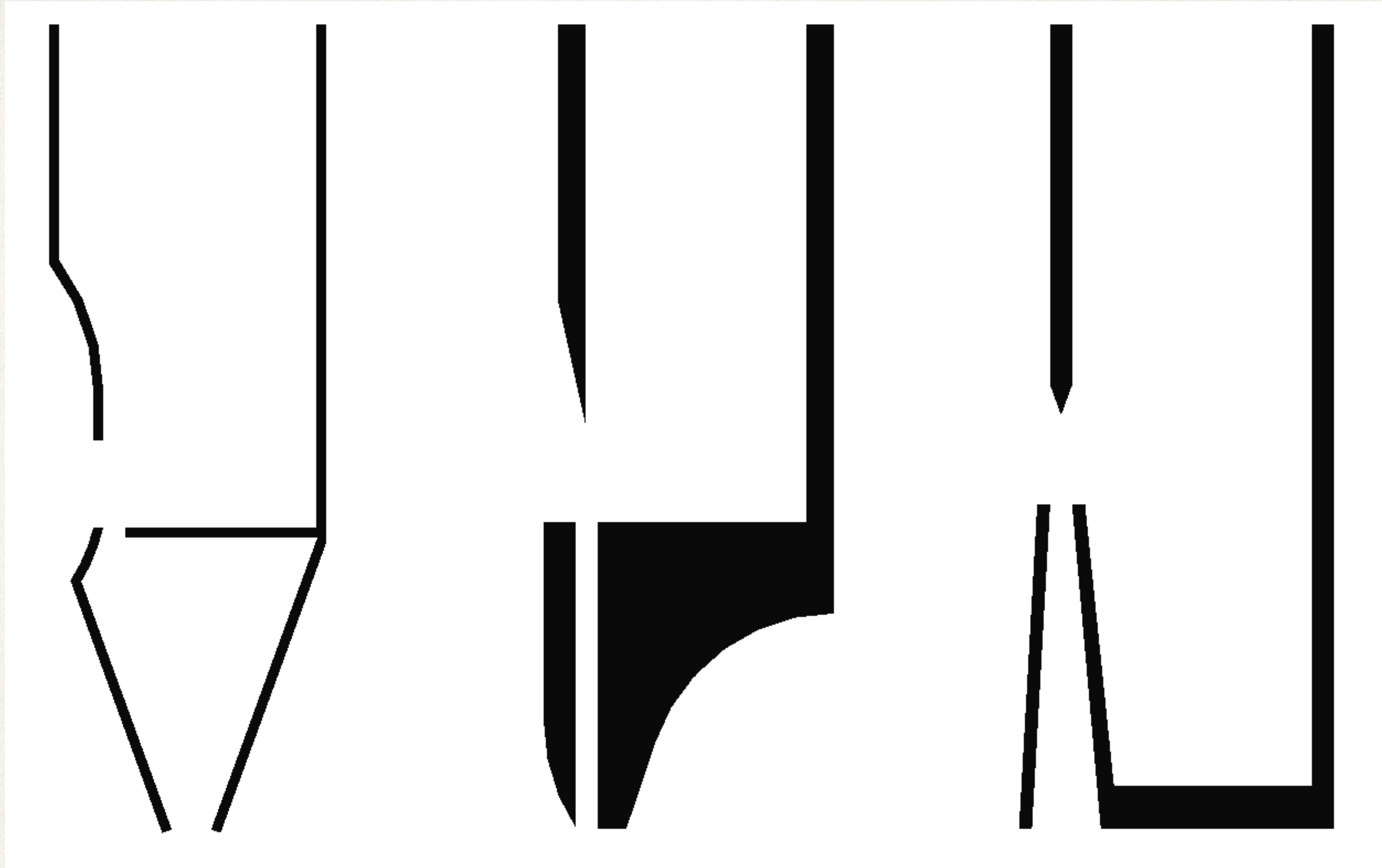

Orgelpfeife

Blockflöte

Labialpfeife  
zum 3d-drucken



# FreeCAD vs. OpenSCAD

---

Plastik ?

---



